

Integrated Packaging for System Thermal Management

HEXIM™

HEXIM™ is an economical insulation housing providing convective (or conductive) system thermal management with integrated air manifolds. HEXIM™ increases overall system efficiency by routing recuperated heat via integrated ducting.

HEXIM™ solutions are made by mass production techniques, allowing complex shapes at competitive costs. Through manufacturing knowledge and expertise in thermal management techniques, HEXIM™ insulation housings can reduce the number of components and simplify assembly. ENrG uses advanced ceramic materials and coatings resulting in minimal-to-no shedding. HEXIM™ is odor-free.

ENrG works with each customer to add functionality to insulation in a compact design. With the ability to include air manifolds, customize wall thicknesses, embed mechanical or thermal inserts and other functional details, ENrG combines your specific needs into a simpler, more efficient design.

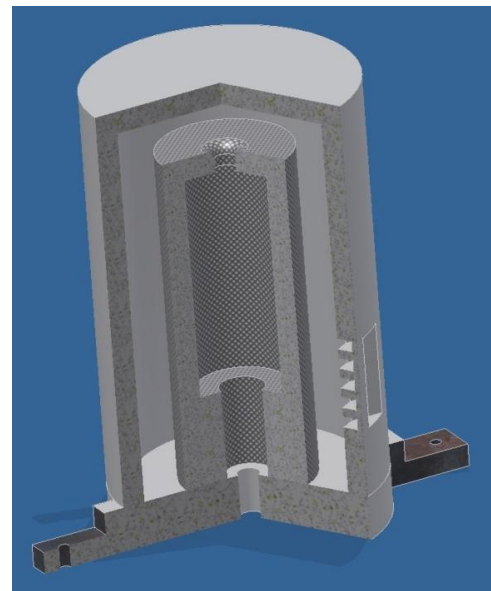

ENrG Inc. Takes Ideas to Reality

As a developer and manufacturer of critical ceramic components for diverse energy applications, ENrG Inc. is a technology leader in the **Power Generation, System Management and Environmental Control** industry segments.

Starting with our Thin E-Strate™ substrate material as the building block we have developed ThinESC™, a highly durable and flexible membrane integral to commercializing fuel cell systems. HEXIM™ provides insulation, a thermal transport mechanism and air manifolds in integrated packaging solutions. Separation membranes aid in the capture of CO₂, transport ions and remove contamination for improved environmental control.

Learn more about how ENrG Inc. can help you take ideas to reality.

For more information contact:

Kathy Olenick — 716.873.2939 ext. 210 — kolenick@enrg-inc.com

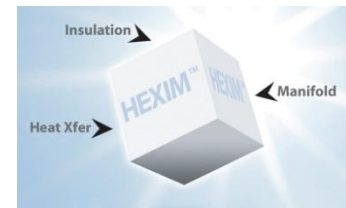

Integrated Packaging for System Thermal Management



HEXIM™ Attributes:

- Molded to desired shape and thickness (0.635 cm. minimum)
- Can be machined, post molding, for more critical geometries
- Capability to customize with integrated fasteners, springs, inserts and coatings
- Usable in system operating temperatures up to 1260 C
- Moisture and oil resistant
- High thermal shock resistance
- Optional coatings for wear resistance, improved thermal conductivity or increased strength
- Thermal control of high temperature core, yet external housing safe to touch
- Stronger than microporous materials
- More thermally conductive than dense ceramics
- Fuel manifolds can be inserted into the molded housings

ENrG works with customers' system designers to propose a HEXIM™ concept, review modeling results, build a prototype and optimize an insulation housing for high volume manufacturing.

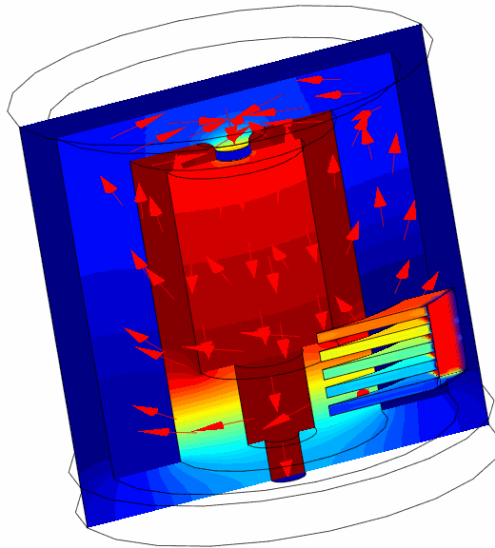
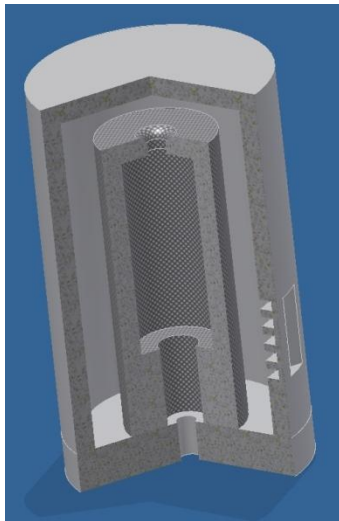

Learn more about how ENrG Inc. can help you take ideas to reality.

For more information contact:

Kathy Olenick — 716.873.2939 ext. 210 — kolenick@enrg-inc.com